



## Hand chain hoist model VSIII

Capacity 250 - 5000 kg

The newly designed hand chain hoist VSIII is an innovative further development introduced by Yale. The improved hand chain guide prevents canting or jamming of the hand chain, leading to a smooth running of the chain. High quality bearings on side plates, gearbox and load chain sheave ensure smooth operation of load chain and drive pinion.

Optimized hand forces set standards for easy operation.

### Features

- Strong bolts between side plates and housing cover and the reinforced hand wheel cover ensure increased stability.
- Precision machined guide rollers ensure smooth running of the load chain.
- High quality bearings for gearbox, side plates and load chain sheave permit a long service life.
- Zinc-plated and yellow-chromated brake parts and guide rollers ensure increased corrosion protection.
- Zinc-plated load chain as standard for added corrosion protection.

### Options

- Overload protection device
- Chain container



Load chain sheave with needle bearing



Side plate with ball bearing



Housing cover with ball bearing

## Technical data model VSIII

Model	EAN-No. 4025092*	Capacity in kg/ number of chain falls	Chain dimensions d x p mm	Lift per 1 m hand chain overhaul mm	Handle pull at WLL daN	Weight at standard lift (3 m) kg
VSIII 0,25/1	*665322	250/1	4x12	50	20	3.9
VSIII 0,5/1	*949545	500/1	5x15	26	21	9.0
VSIII 1,0/1	*949927	1000/1	6x18	24	24	11.5
VSIII 1,5/1	*593854	1500/1	8x24	17	30	17.5
VSIII 2,0/1	*949934	2000/1	8x24	19	32	19.0
VSIII 2,0/2	*949941	2000/2	6x18	15	29	17.3
VSIII 3,0/1	*949958	3000/1	10x30	12	40	31.0
VSIII 3,0/2	*949965	3000/2	8x24	10	37	27.0
VSIII 5,0/2	*949972	5000/2	10x30	8	41	43.0

## Dimensions model VSIII

Model	VSIII 0,25/1	VSIII 0,5/1	VSIII 1,0/1	VSIII 1,5/1	VSIII 2,0/1	VSIII 2,0/2	VSIII 3,0/1	VSIII 3,0/2	VSIII 5,0/2
A min., mm	290	350	380	450	460	490	570	580	700
B, mm	12	21	27	33	37	37	46	46	56
C, mm	26	28	32	37	41	41	44	44	50
D, mm	11	16	19	22	27	27	31	31	37
E, mm	118	145	158	180	205	170	240	220	250
F, mm	113	140	155	175	180	155	210	175	190
G, mm	65	80	87	85	94	87	110	94	95
H, mm	48	60	68	90	86	68	100	81	95
K, mm	190	240	270	300	320	285	370	340	410

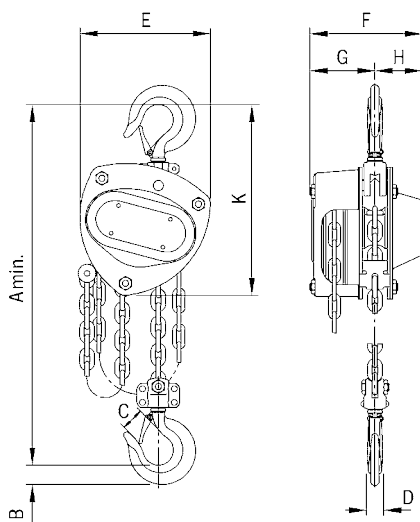

Model VSIII, 250 - 3000 kg, single fall

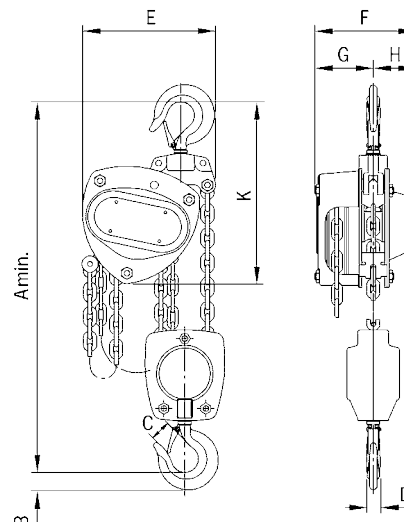

Model VSIII, 2000 - 5000 kg, double fall



Option: Chain container

## INFO

Yale hoists and trolleys are not designed for passenger elevation applications and must not be used for this purpose.